



Knock Down Fittings

- What does KD stand for? _____
- Why were KD fittings were originally designed? _____

- What materials are used in the making of these fittings? _____
- _____

- What are the advantages of KD Fittings?
- _____

- What are the disadvantages of KD Fittings?
- _____



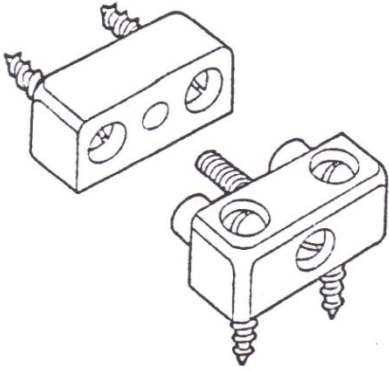

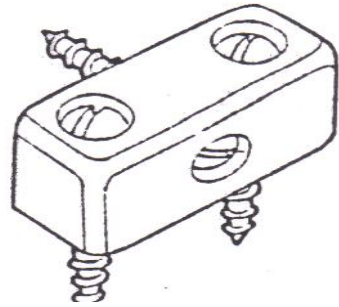

J. Byrne 2012

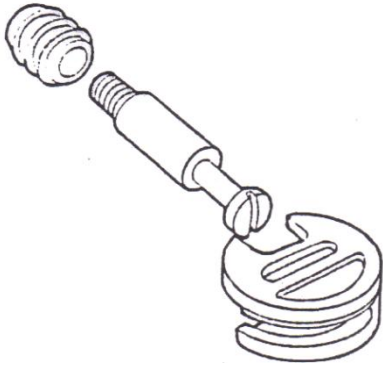

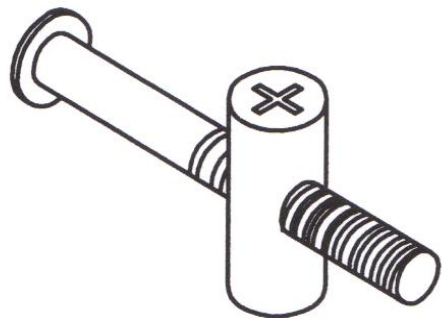

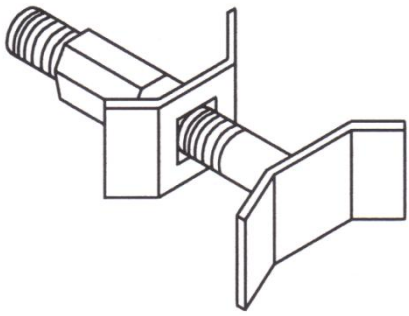

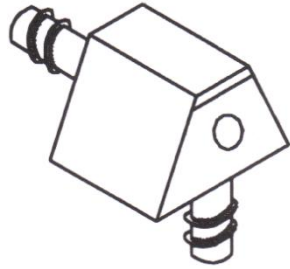

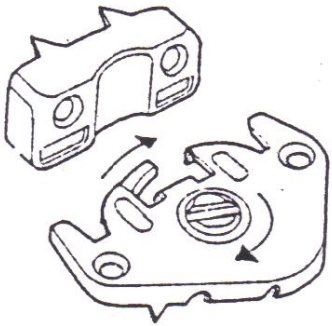

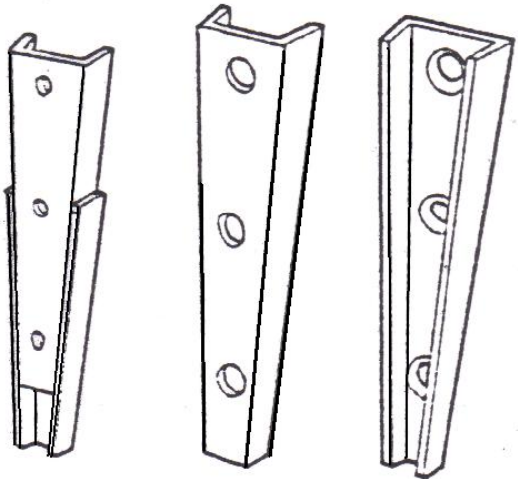



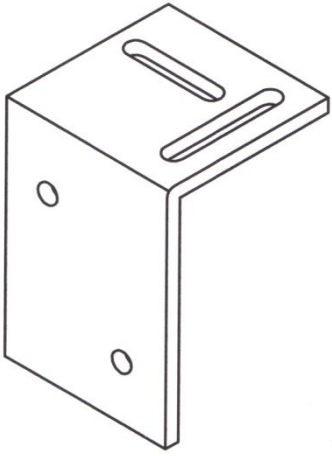

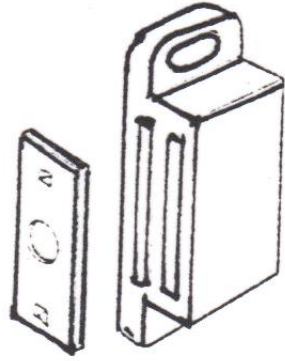

J. Byrne 2012

